

METRIC

MIL-PRF-85045/13C
16 September 1999
SUPERSEDING
MIL-C-85045/13B
26 May 1995

PERFORMANCE SPECIFICATION SHEET

CABLE, FIBER OPTIC, EIGHT FIBERS, CABLE CONFIGURATION TYPE 2 (OFCC),
APPLICATION B (SHIPBOARD), CABLE CLASS SM AND MM, (METRIC)

This specification is approved for use by all Departments and
Agencies of the Department of Defense.

The requirements for acquiring the product described herein shall
consist of this specification and MIL-PRF-85045.

CLASSIFICATION:

Fiber optic cable configuration type: 2 (OFCC).

Fiber Cable Class: MM (graded-index, glass core and glass cladding, multimode).
SM (dispersion-unshifted, glass core and glass cladding,
single-mode).

DESIGN AND CONSTRUCTION:

Fiber:

Class MM fibers shall be in accordance with MIL-PRF-49291/6.
Class SM fibers shall be in accordance with MIL-PRF-49291/7.

Buffer diameter: $900 \pm 50 \mu\text{m}$.

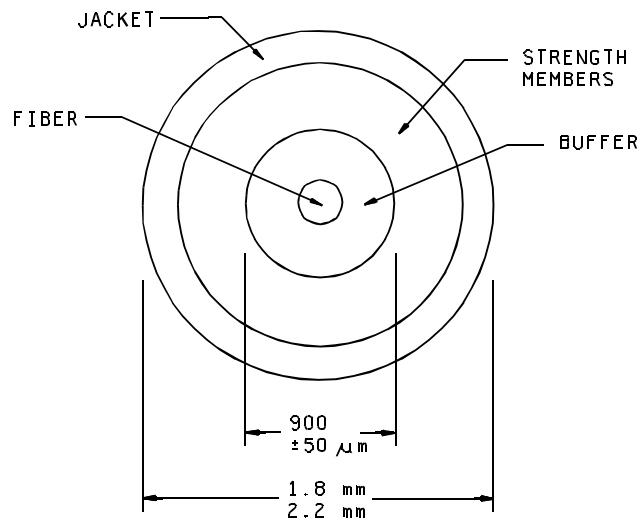

NOTE:

1. Dimensions are in millimeters.

FIGURE 1. Optical fiber cable component.

OFCC:

Dimensions and configuration: See figure 1.

Mass per unit length: ≤ 15 kg/km.

Short term minimum bend diameter: Eight times the OFCC outer diameter.

Long term minimum bend diameter: Sixteen times the OFCC outer diameter.

Tensile loading: ≥ 270 N.

Dynamic bend tensile load: 90 N minimum.

Jacket material: The OFCC jacket shall be composed of a low halogen, low smoke, low toxicity polymer material.

Finished cable:

Dimensions and configuration: See figure 2. Eight OFCC units shall be helically laid over the central member. The minimum outer jacket thickness shall be not less than 1.0 mm (establishes compatibility with termination and penetration devices).

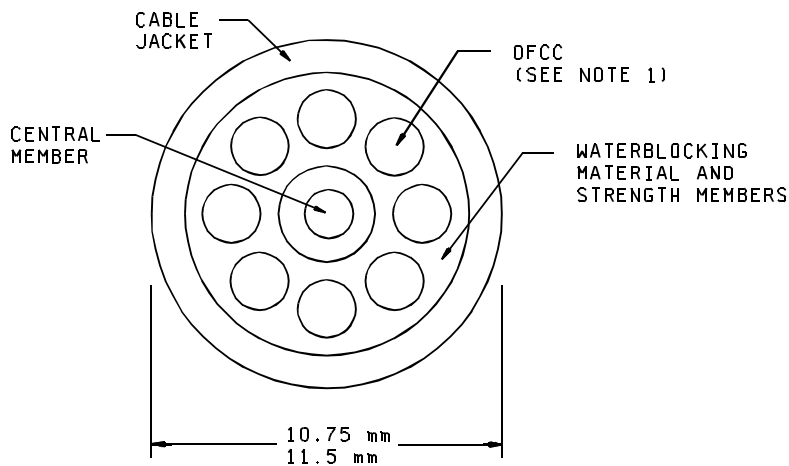

NOTES:

1. OFCC - Optical fiber cable component.
2. Dimensions are in millimeters.

FIGURE 2. Eight OFCC fiber optic cable.

Number of fibers: 8 (one per OFCC).

Concentricity: ≥ 0.65 .

Jacket material: The overall jacket shall be composed of a low halogen, low smoke, low toxicity polymer material.

Mass per unit length: ≤ 175.0 kg/km.

Short term minimum bend diameter: Eight times the cable outer diameter. (The short term minimum bend diameter is to be used in all environmental and mechanical tests which specify a cable minimum bend diameter).

Long term minimum bend diameter: Sixteen times the cable outer diameter.

Minimum continuous length: The minimum continuous length of all cables shall be not less than 0.5 km. If lengths less than 0.5 km are specified in the purchase order, Quality Conformance Inspection shall be performed on test specimens not less than 0.5 km in length from which the purchase order lengths are cut.

PERFORMANCE REQUIREMENTS:

Optical properties:

Maximum attenuation rate: 4.5 dB/km at 850 ± 20 nm, 2.0 dB/km at 1300 ± 20 nm for class MM fiber.
1.0 dB/km at 1310 ± 20 nm and 1550 ± 20 nm for class SM fiber.

Bandwidth: Fiber with a minimum bandwidth of 500 Mhz-km at 1300 nm shall be used (multimode cables only).
Bandwidth is not specified at 850 nm.

Change in optical transmittance: Measurements to be made at 1300 ± 20 nm.

Crosstalk: Applicable.

Mechanical properties:

Tensile loading and elongation: Applicable, tensile loading ≥ 2700 N.

Operating tensile loading: Applicable.

Cyclic flexing: 500 cycles at $25^{\circ}\text{C} \pm 2^{\circ}\text{C}$ and 100 cycles at $-28^{\circ}\text{C} \pm 2^{\circ}\text{C}$. Change in optical transmittance measurements are to be made every 100 cycles for the 500 cycle exposure and every 25 cycles for the 100 cycle exposure. Each change in optical transmittance measurement shall be performed with the test specimen in the same position in the test cycle. The cycling may be halted to perform the change in optical transmittance measurement.

Crush: Applicable.

Cable twist bending: 500 cycles at $25^{\circ}\text{C} \pm 2^{\circ}\text{C}$ and 100 cycles at $-28^{\circ}\text{C} \pm 2^{\circ}\text{C}$. Change in optical transmittance measurements are to be made every 100 cycles for the 500 cycle exposure and every 25 cycles for the 100 cycle exposure. Each change in optical transmittance measurement shall be performed with the test specimen in the same position in that test cycle. The cycling may be halted to perform the change in optical transmittance measurement.

Radial compression: Applicable.

Impact: 50 cycles at $25^{\circ}\text{C} \pm 2^{\circ}\text{C}$ and 20 cycles at $-40^{\circ}\text{C} \pm 2^{\circ}\text{C}$.

Hosing: Both low pressure and hydrostatic pressure are applicable.

Hydrostatic: 7.7 MPa for M85045/13-01P and M85045/13-02P.

Dripping: Applicable.

Environmental:

Temperature range:

Operating: -28°C to 65°C .
Nonoperating: -40°C to 70°C .
Storage: -40°C to 70°C .

MIL-PRF-85045/13C

Temperature cycling: Change in optical transmittance measurements may be made periodically. At a minimum, one optical transmittance measurement shall be made over a period of 1 hour at the end of each temperature plateau.

Temperature humidity cycling: Change in optical transmittance measurements may be made periodically. At a minimum, one optical transmittance measurement shall be made at the end of each temperature plateau.

Storage temperature: Applicable.

Weathering: Applicable.

Fluid immersion: Exposure to automobile gasoline and tap water are not required and the test temperature for lubricating oil exposure shall be 73°C to 77°C. The tensile strength retention of the cable jacket material after exposure to hydraulic fluid shall be not less than 30 percent.

Flame extinguishing: Applicable.

Smoke generation and flame propagation: Applicable, except the pass/fail criteria shall be as follows. The peak optical density and the average optical density of smoke produced shall be not greater than 0.5 and 0.15 respectively. In addition, the flame spread-time product at the 10 minute point shall be not greater than 27.5 meters-minutes when calculated in accordance with ASTM-E-84.

Shock: Applicable.

Paint susceptibility: Applicable.

Electromagnetic effects: Applicable.

Chemical properties:

Halogen content: < 0.2 percent.

Part or Identifying Number (PIN) (see table I):

M85045/13-01P (Multimode).
M85045/13-02P (Single-mode).

"P" designates 7.7 Mpa hydrostatic pressure proof cable.

TABLE I. Supersession data.

PIN	Superseding
M85045/13-01P	M85045/13-01
	M85045/13-01N
	M85045/13-01T
M85045/13-02P	M85045/13-02
	M85045/13-02N
	M85045/13-02T

Qualification by similarity.

Manufacturers who produce products for MIL-PRF-85045/17 and products for this specification sheet and are qualified under MIL-PRF-85045/17 and pass the attenuation rate, low temperature flexibility (cold bend), impact (low temperature only), low pressure hosing, cable abrasion resistance, smoke generation and flame propagation, flame extinguishing, cable jacket material tensile strength and elongation, durability of identification, size, cable life (both jacket material and complete cable), cyclic flexing, electromagnetic effects, dripping, weathering, fluid immersion, plait susceptibility, acid gas generation, halogen content, toxicity index, and fungus inspections specified herein, are qualified under this specification sheet. This qualification by similarity is applicable if the only difference between the previously qualified MIL-PRF-85045/17 cable and this MIL-PRF-85045/13 cable is the outer jacket material. If the MIL-PRF-85045/13 cable is identical to the previously qualified MIL-PRF-85045/17 cable, no testing is required for qualification. A certificate of the compliance may be submitted in lieu of performing the acid gas generation, halogen content, toxicity index and fungus inspections. Testing may be performed on a single length of cable, with a minimum length of 0.5 km.

Manufacturers who are qualified under MIL-PRF-85045/17 for both multimode and single-mode fiber cable and are qualified under this specification sheet for multimode fiber cable and whose single-mode fiber cable passes the visual and mechanical, attenuation rate, temperature cycling, humidity, storage temperature, cyclic flexing, crush, cable twist-bending, impact (low temperature only), tensile loading and elongation, operating tensile loading, thermal shock and dynamic bend inspections specified herein, are qualified under this specification sheet for single-mode fiber cable. This qualification by similarity is applicable if the only difference between the previously qualified cable and the cable under test is that the optical fiber has been changed from a multimode fiber to a single-mode fiber. Testing may be performed on either one or two lengths of cable, each with a minimum length of 0.5 km. Test order must be observed up to and including the storage temperature test. If only one cable length is used the thermal shock test shall be performed after the storage temperature test.

Custodians:

Army - CR
Navy - SH
AIR FORCE - 11
NASA - NA

Preparing activity:

Navy - SH

Agent:

DLA-CC

Review activities:

Army - AR, AV, MI
Navy - EC, YD
Air Force - 02, 19, 80, 99
DLA - CC

(Project 6015-0034-01)